

# SOJAG ■ I

produits saisonniers • seasonal products

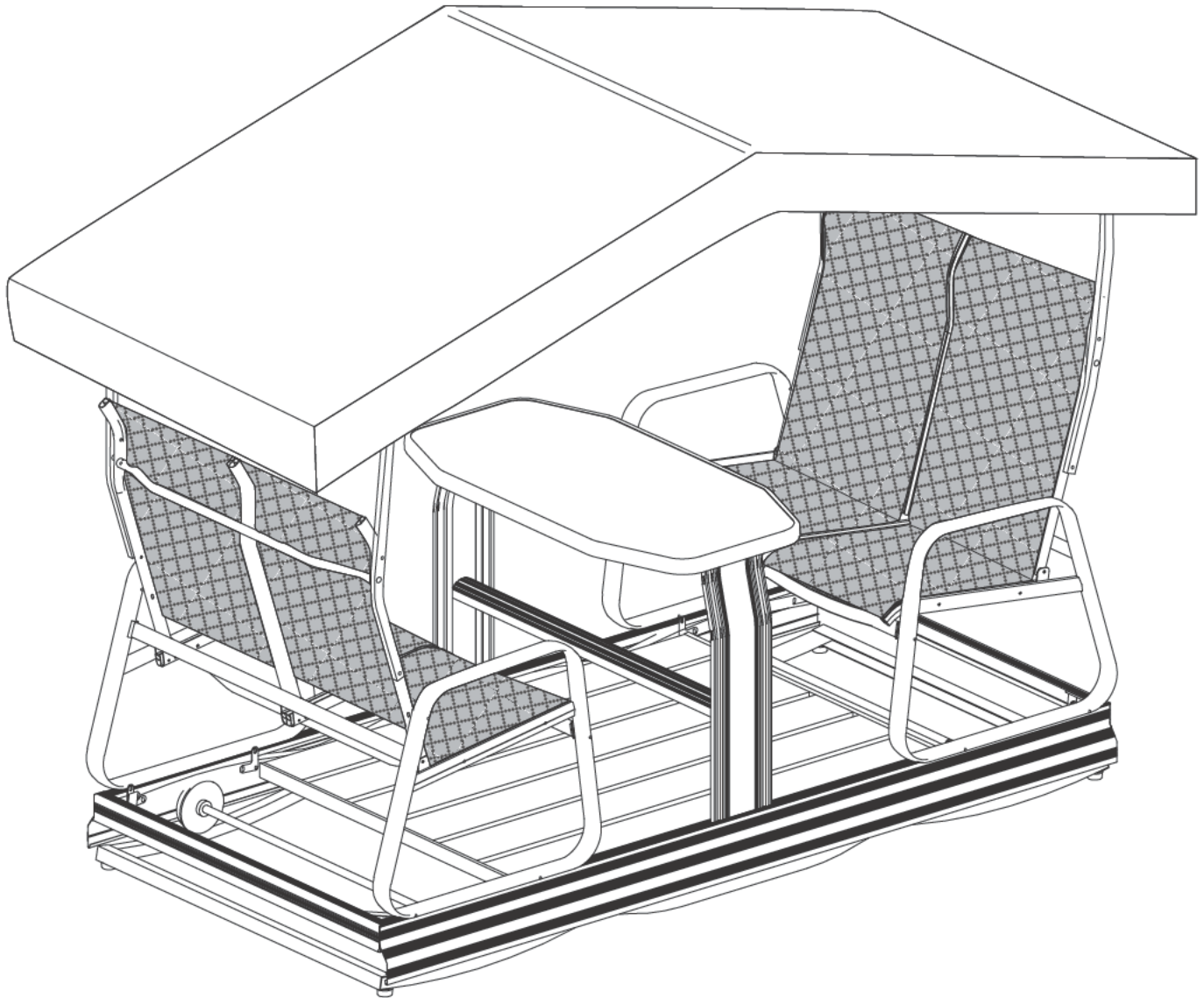

---

## Owner's Manual

Bridge  
Garden Swing

## Guide de l'utilisateur

Bridge  
Balançoire de jardin

Sojag code: 113-6156782

UPC code: 772840156782

Code Sojag : 113-6156782

Code CUP : 772840156782

**NOTE:**

Parts not shown to actual size and not to scale.

**NOTE :**

Le matériel n'est pas représenté à l'échelle.

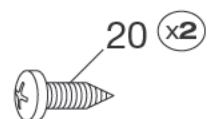
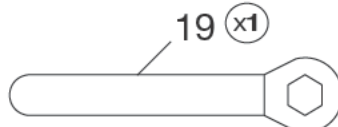
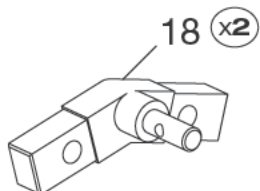
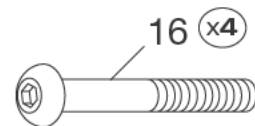
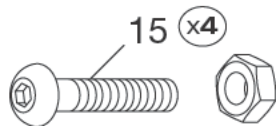
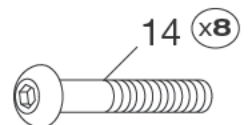
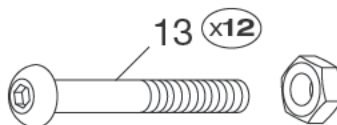
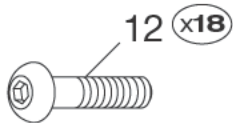
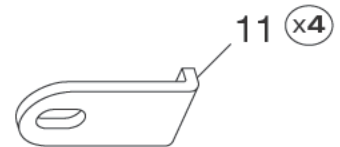
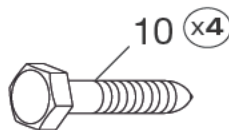
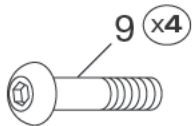
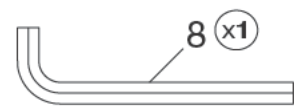
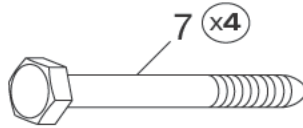
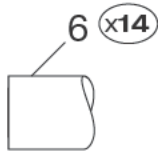
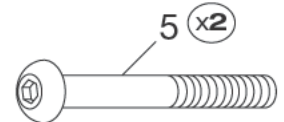
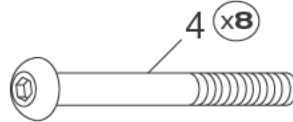
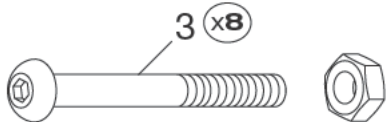
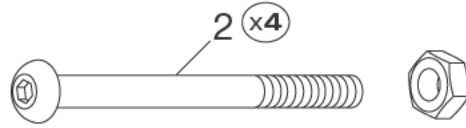
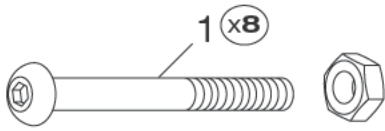

# IMPORTANT

Read the owner's manual and make sure all parts are included PRIOR to the start of assembly.

# IMPORTANT

Lire le guide de l'utilisateur AVANT de débiter l'assemblage du produit.

Item	Description	Qty
1	Screw with Nut M6X70	8
2	Screw with Nut M6X105	4
3	Screw with Nut M6X65	8
4	Screw M6X70	8
5	Screw M6X50	2
6	Spacer Ø17x17	14
7	Screw St6X60	4
8	Allen Key	1
9	Screw M6X15	4
10	Screw St6X30	4
11	Glass Support	4
12	Screw M6X20	18
13	Screw with Nut M6X40	12
14	Screw M6X30	8
15	Screw with Nut M6X22	4
16	Screw M6X45	4
18	Connector	2
19	Wrench	1
20	Screw St4x12	2

Pièce	Description	Qté
1	Vis et écrou M6X70	8
2	Vis et écrou M6X105	4
3	Vis et écrou M6X65	8
4	Vis M6X70	8
5	Vis M6X50	2
6	Entretoise Ø17x17	14
7	Vis St6X60	4
8	Clé hexagonale	1
9	Vis M6X15	4
10	Vis St6X30	4
11	Support de vitre	4
12	Vis M6X20	18
13	Vis et écrou M6X40	12
14	Vis M6X30	8
15	Vis et écrou M6X22	4
16	Vis M6X45	4
18	Connecteur	2
19	Clé plate	1
20	Vis St4x12	2



# PARTS LIST

# LISTE DE PIÈCES

**NOTE:**

Parts not shown to actual size and not to scale.

**NOTE :**

Le matériel n'est pas représenté à l'échelle.

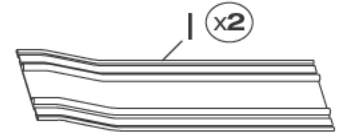
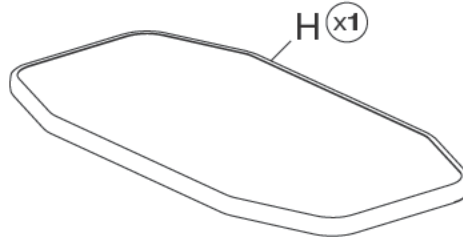
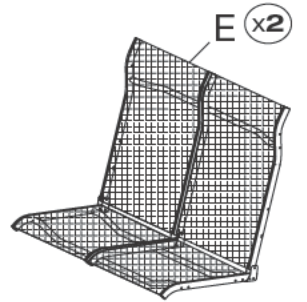
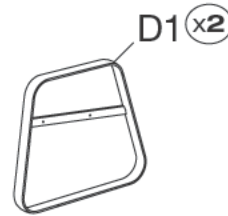
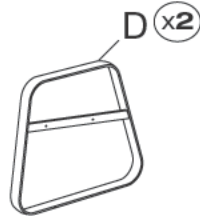
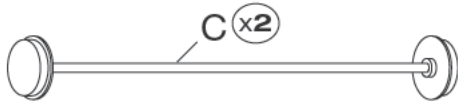
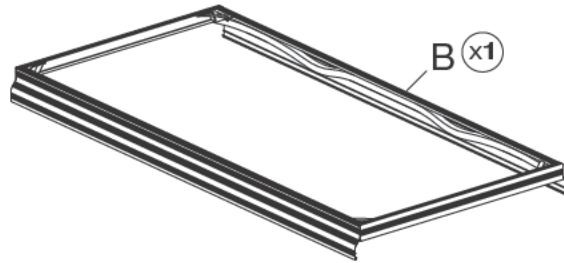
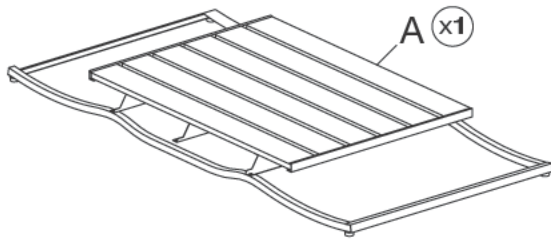

Item	Description	Qty
A	Floor	1
B	Floor Frame	1
C	Wheel Set with Bar	2
D	Right Arm	2
D1	Left Arm	2
E	Seat	2
F	Under Bench Front Bar	2
G	Under Bench Back Bar	2
H	Table	1
I	Table Leg	2

Pièce	Description	Qté
A	Plancher	1
B	Cadre de plancher	1
C	Ensemble de roues avec barre	2
D	Bras droit	2
D1	Bras gauche	2
E	Banc	2
F	Barre avant sous banc	2
G	Barre arrière sous banc	2
H	Table	1
I	Montant de table	2

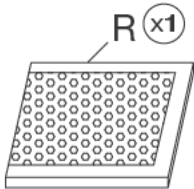
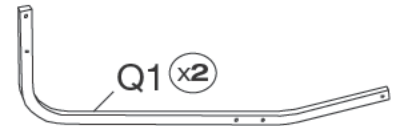
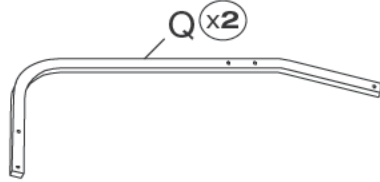
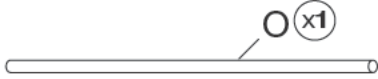
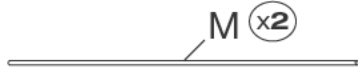
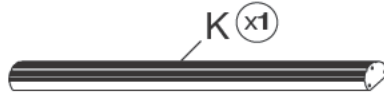
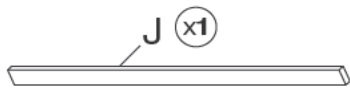

Item	Description	Qty
J	Under Table Bar	1
K	Foot Rest	1
L	Table Support	2
M	Roof Bar	2
N	Roof Bar	2
O	Central Roof Bar	1
P	Roof Bar	2
Q	Roof Structure	2
Q1	Roof Structure	2
R	Roof	1
S	Roof Structure Bar	4

Pièce	Description	Qté
J	Barre sous table	1
K	Repose-pieds	1
L	Support de table	2
M	Barre de toit	2
N	Barre de toit	2
O	Barre centrale de toit	1
P	Barre de toit	2
Q	Montant de toit	2
Q1	Montant de toit	2
R	Toit	1
S	Barre de structure de toit	4

# Step 1

1.1 Attach the under table bar (J) and the foot rest (K) to the table legs (I) using the screws (12) as illustrated.

# Étape 1

1.1 Attacher la barre sous table (J) et le repose-pieds (K) aux montants de table (I) en utilisant les vis (12) tel qu'illustré.

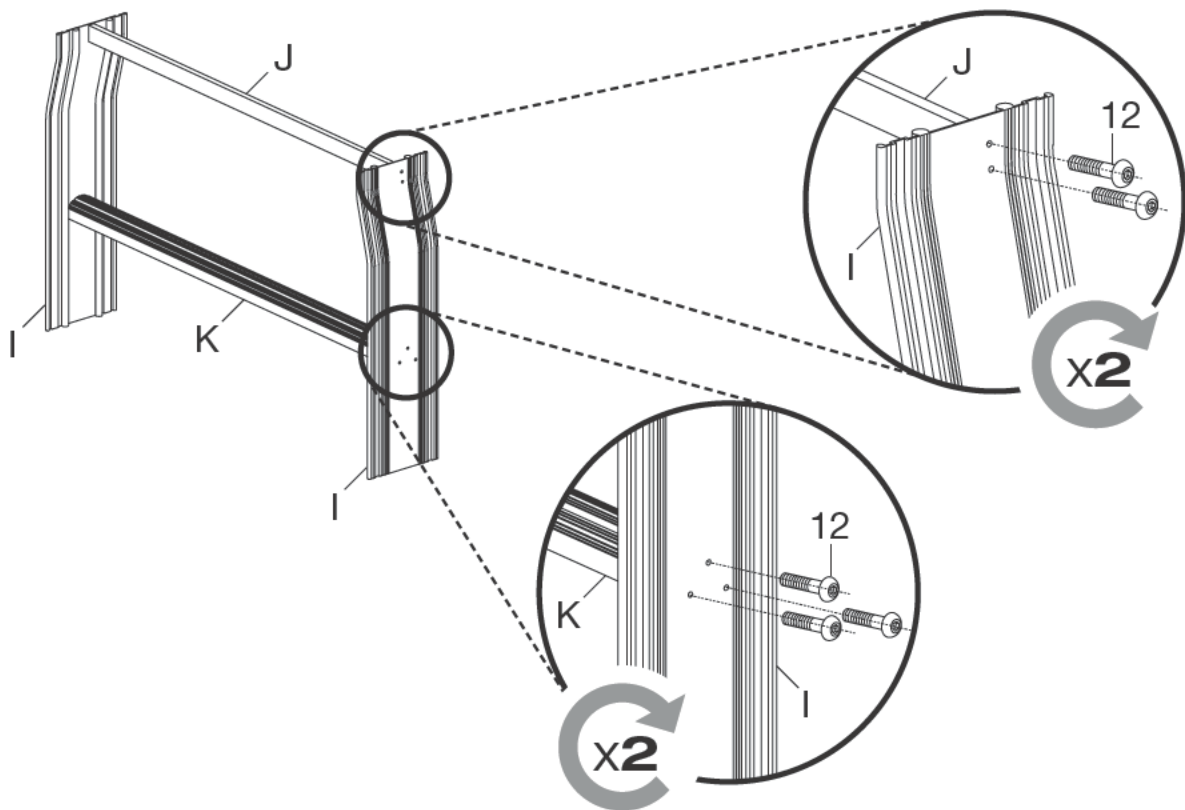

Parts required for this step / Pièces requises pour cette étape :

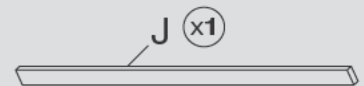
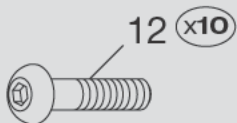

## Step 2

2.1 Attach the table supports (L) to the table legs (I) using the screws (10) as illustrated.

## Étape 2

2.1 Attacher les supports de table (L) aux montants de table (I) en utilisant les vis (10) tel qu'illustré.

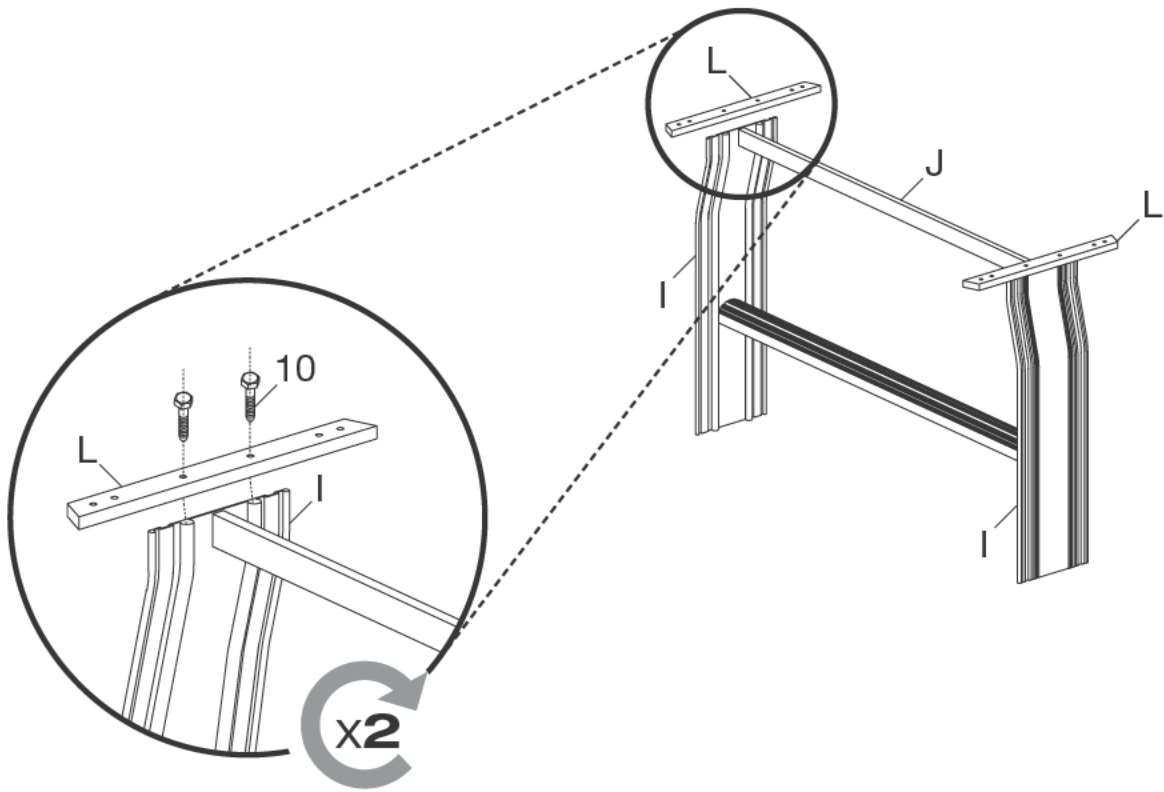

Parts required for this step / Pièces requises pour cette étape :

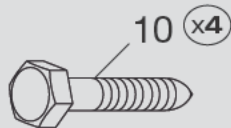





**IMPORTANT:**

Always install the structure on a level platform, wood or concrete.

**IMPORTANT :**

Toujours installer la structure sur une surface de niveau.

## Step 4

4.1 Attach both table legs (I) to the floor frame (B) using the screws (7) as illustrated.

## Étape 4

4.1 Attacher les deux montants de table (I) au cadre de plancher (B) en utilisant les vis (7) tel qu'illustré.

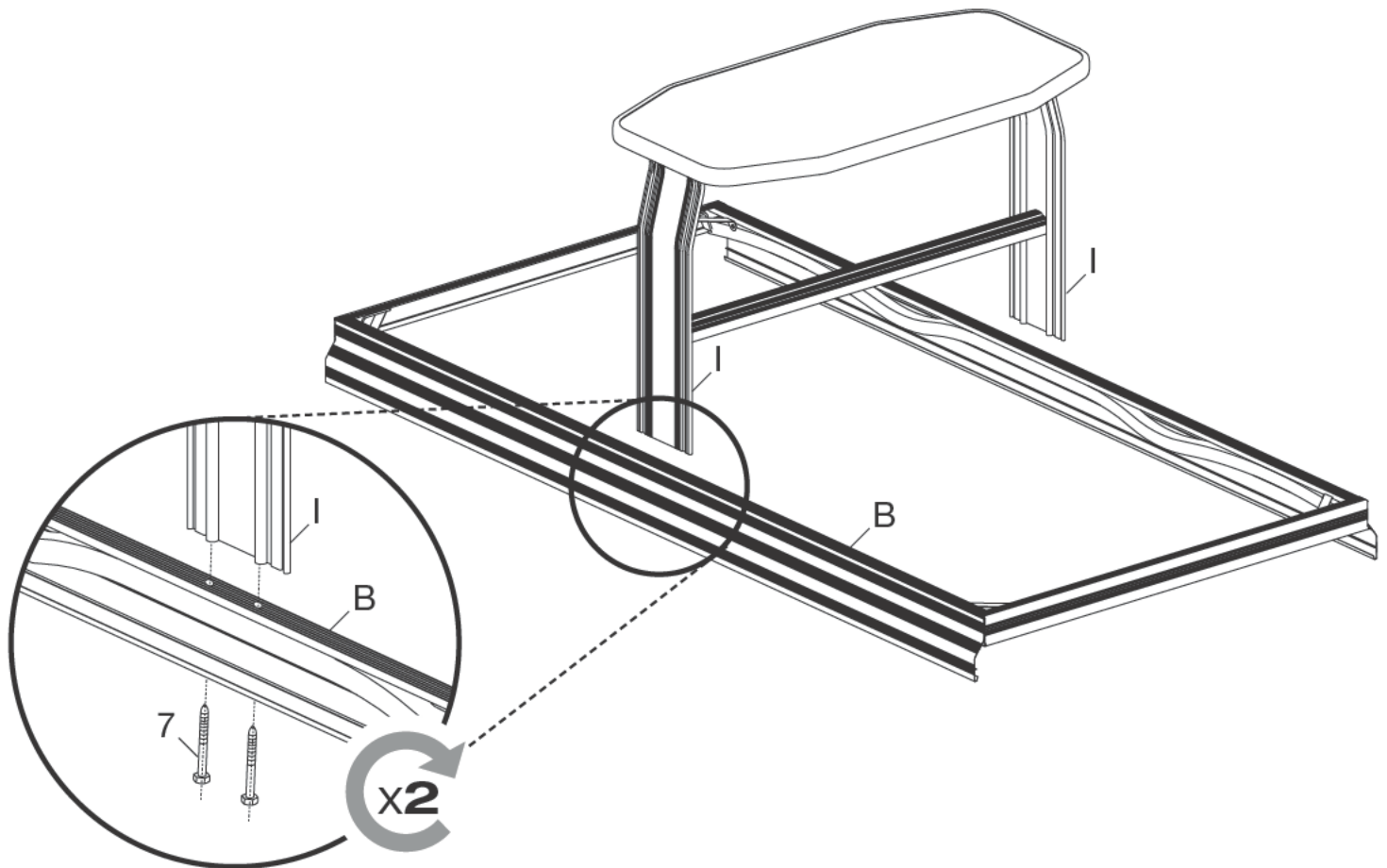

Parts required for this step / Pièces requises pour cette étape :

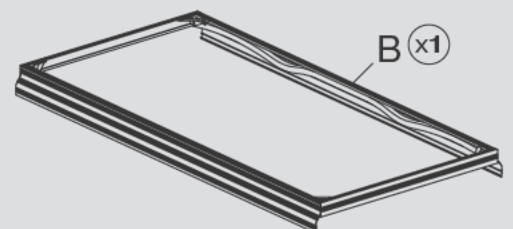
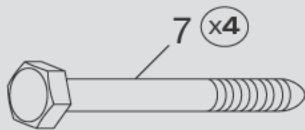

## Step 5

5.1 Place the wheel sets with bars (C) over the rails found on the floor (A).

5.2 Place the floor frame (B) over the floor (A).

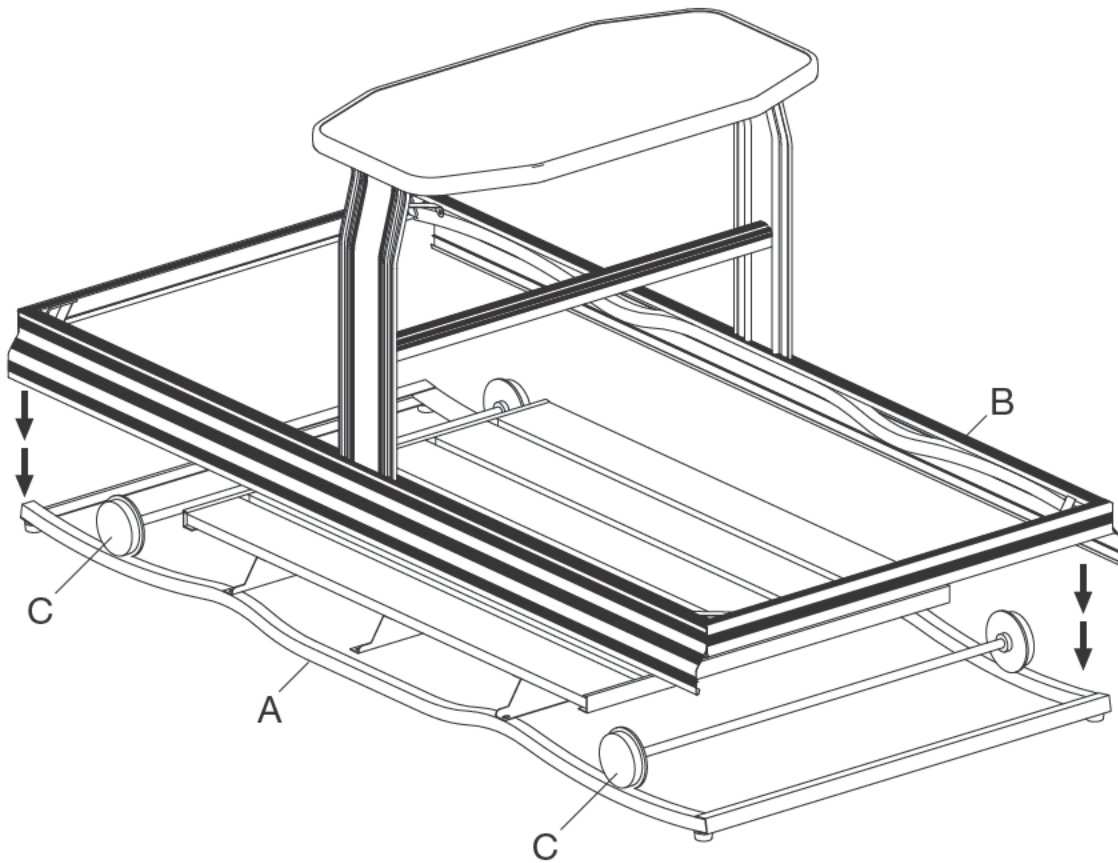

## Étape 5

5.1 Placer les ensembles de roues avec barres (C) sur les rails du plancher (A).

5.2 Placer le cadre de plancher (B) au dessus du plancher (A).

Parts required for this step / Pièces requises pour cette étape :

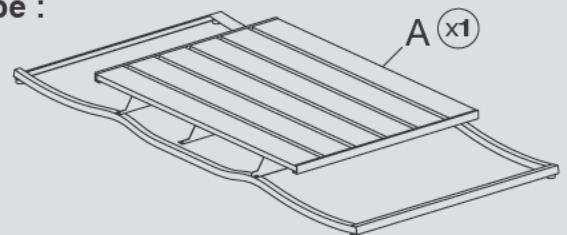
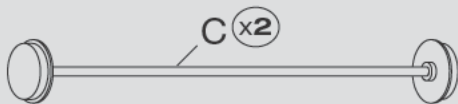

# Step 6

6.1 Install a spacer (6) behind the seat (E) using a screw (5) as illustrated.

Repeat for the second seat (E).

# Étape 6

6.1 Installer une entretoise (6) à l'arrière du banc (E) en utilisant une vis (5) tel qu'illustré.

Répéter pour le deuxième banc (E).

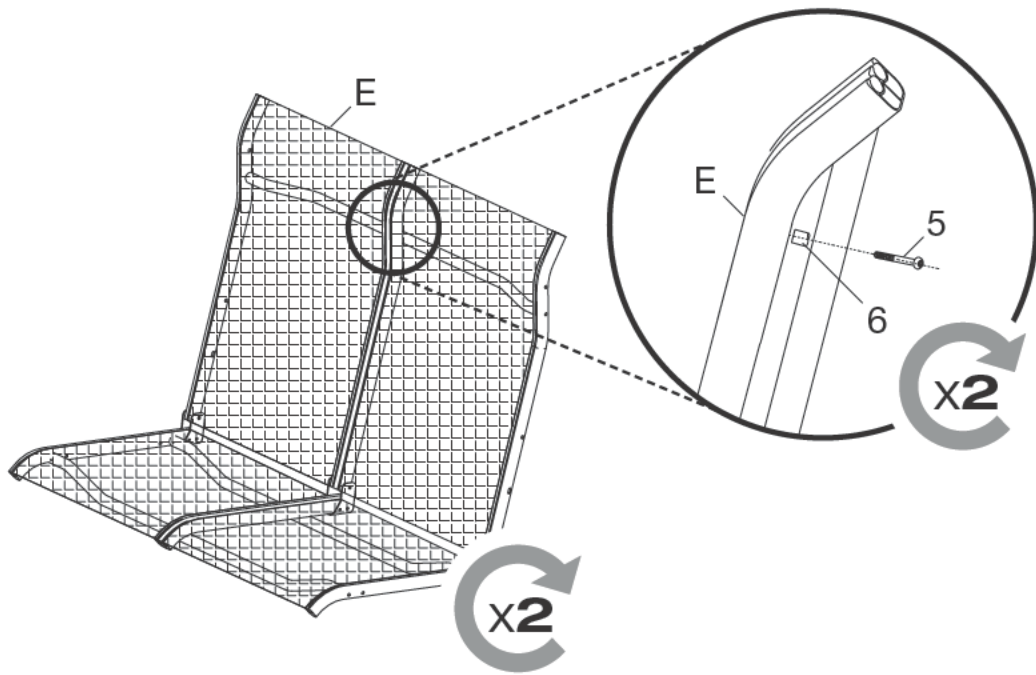

Parts required for this step / Pièces requises pour cette étape :

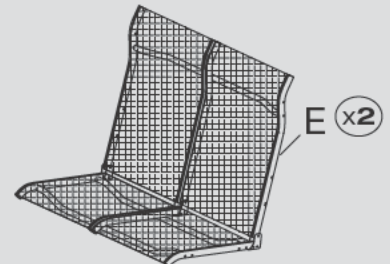
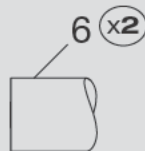
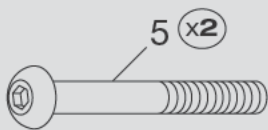

# Step 7

7.1 Attach the under bench back bar (G) to the right arm (D) and to the left arm (D1) using the screws (4) as illustrated.

7.2 Attach the under bench front bar (F) to the right arm (D) and to the left arm (D1) using the screws (4) as illustrated.

Repeat for second seat assembly.

# Étape 7

7.1 Attacher la barre arrière sous banc (G) au bras droit (D) et au bras gauche (D1) en utilisant les vis (4) tel qu'illustré.

7.2 Attacher la barre avant sous banc (F) au bras droit (D) et au bras gauche (D1) en utilisant les vis (4) tel qu'illustré.

Répéter pour l'assemblage du second banc.

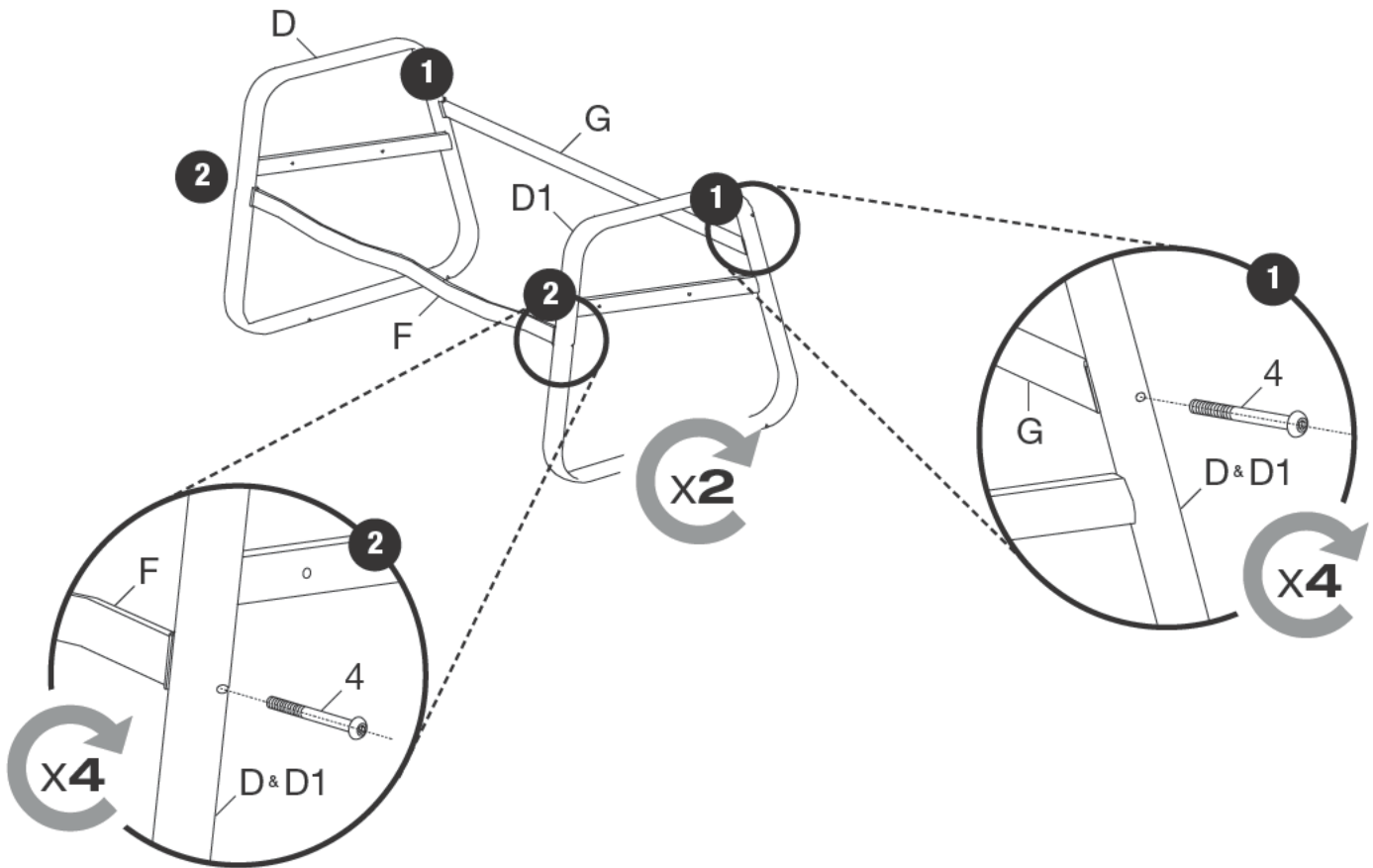

**Parts required for this step / Pièces requises pour cette étape :**

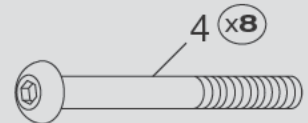
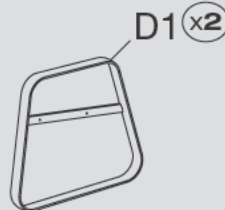
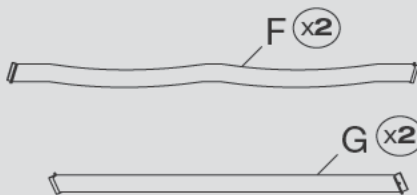
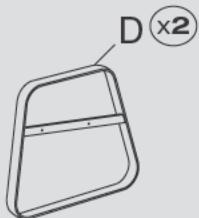

# Step 8

8.1 Attach the seat (E) to the right arm (D) and to the left arm (D1) using the spacers (6) and the proper screws and nuts (2 or 3) as illustrated.

Repeat for the remaining seat (E).

# Étape 8

8.1 Attacher le banc (E) au bras droit (D) et au bras gauche (D1) en utilisant les entretoises (6) et les vis et écrous appropriés (2 ou 3) tel qu'illustré.

Répéter pour le banc (E) restant.

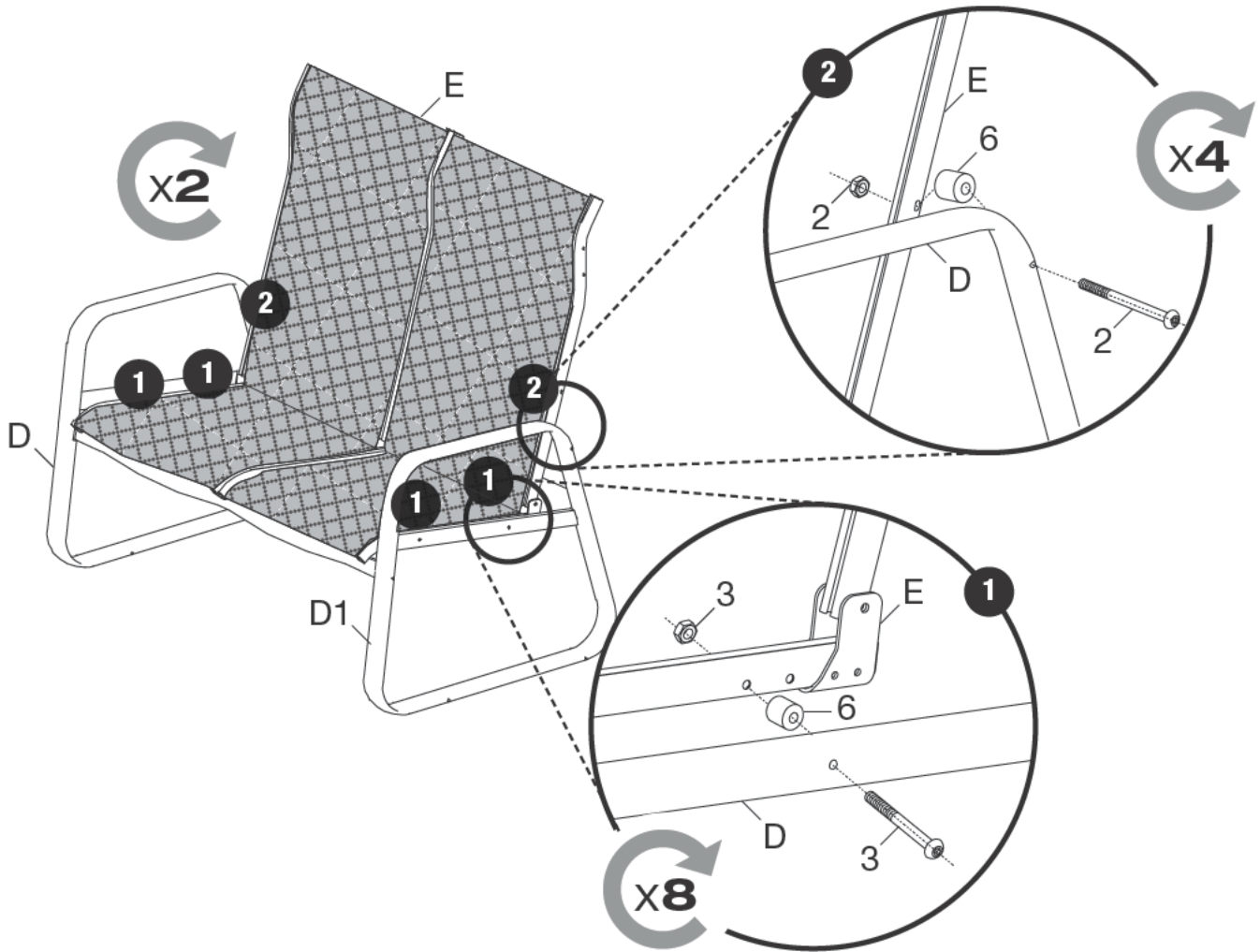

**Parts required for this step / Pièces requises pour cette étape :**

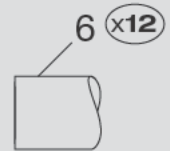
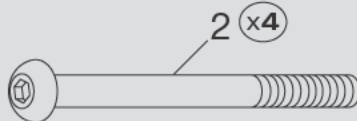
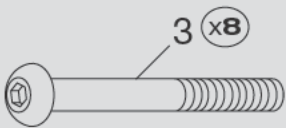

## Step 9

- 9.1 Attach the right arm (D) and the left arm (D1) to the structure using a screw and nut (1) from the outside of the structure as illustrated. Repeat for remaining arms (D and D1).
- 9.2 Attach the seats to the floor frame (B) using the screws (12) from the inside of the structure as illustrated.

## Étape 9

- 9.1 Attacher le bras droit (D) et le bras gauche (D1) à la structure en utilisant une vis et un écrou (1) à partir de l'extérieur de la structure tel qu'illustré. Répéter pour les bras (D et D1) restants.
- 9.2 Attacher les bancs au cadre de plancher (B) en utilisant les vis (12) à partir de l'intérieur de la structure tel qu'illustré.

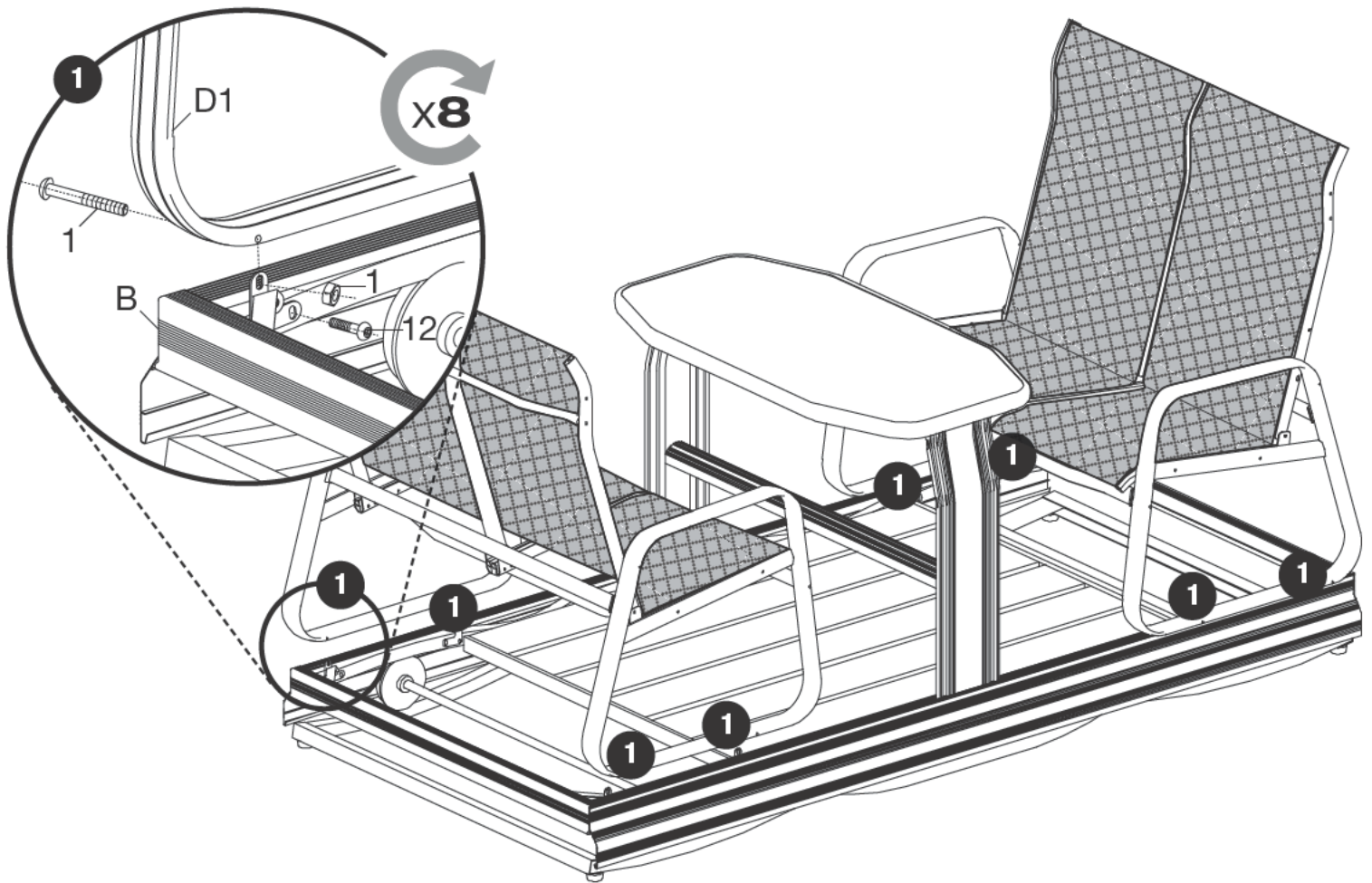

Parts required for this step / Pièces requises pour cette étape :





# Step 10

10.1 Attach a roof structure (Q) and a roof structure (Q1) to the seat (E) using the screws and nuts (13) as illustrated.

Repeat for remaining roof structures (Q and Q1).

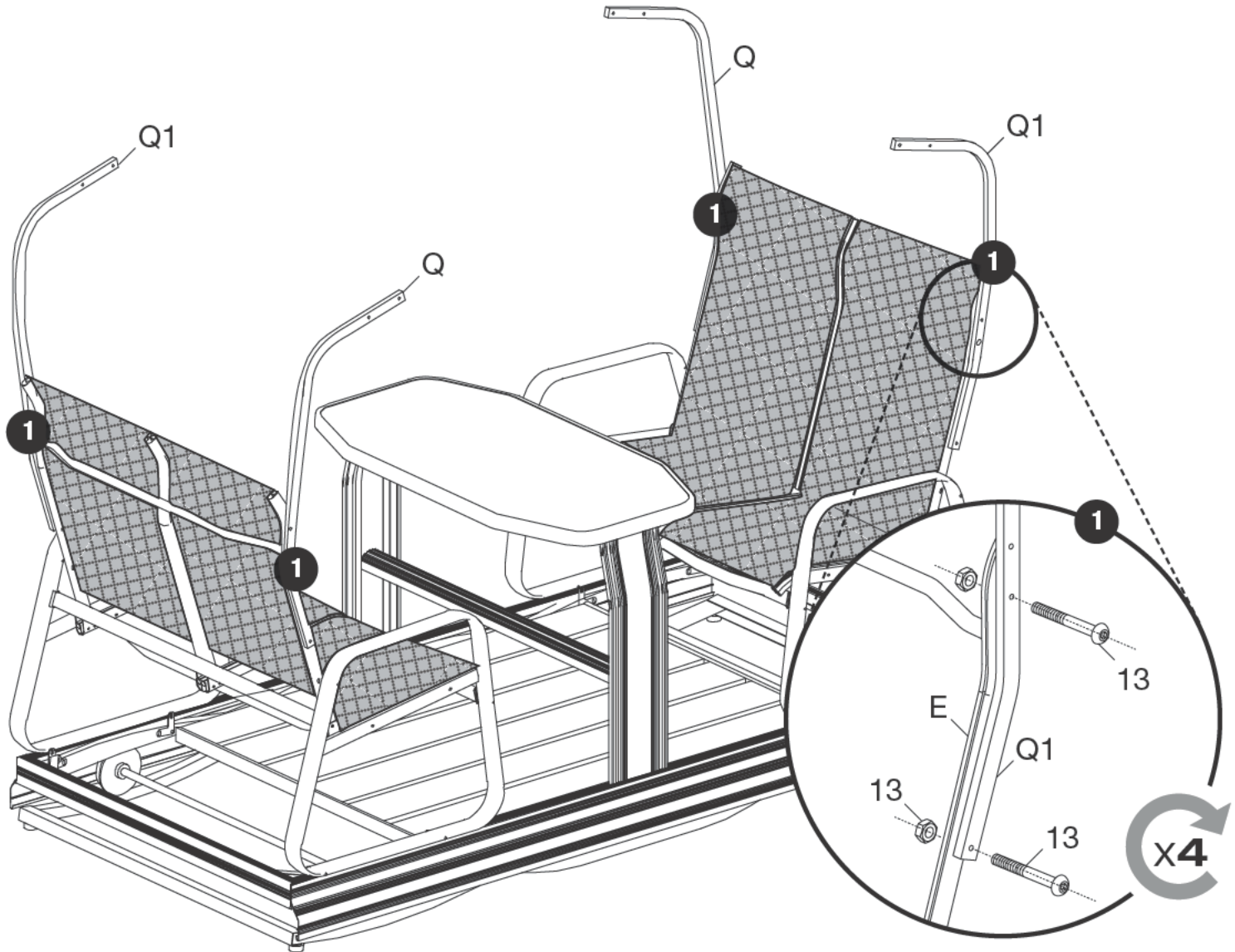

Parts required for this step / Pièces requises pour cette étape :

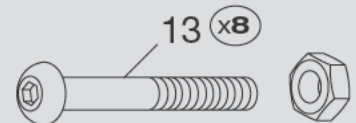
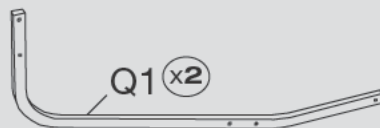
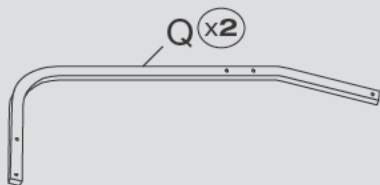

# Step 11

- 11.1 Attach two roof structure bars (S) to a connector (18) using the screws and nuts (15) as illustrated. Repeat for remaining roof structure bars (S).
- 11.2 Join the central roof bar (O) between two connectors (18) as illustrated. Attach using the screws (20).
- 11.3 Attach the roof bars (M) to the roof structure bars (S) using the screws (14) as illustrated.

# Étape 11

- 11.1 Attacher deux barres de structure de toit (S) au connecteur (18) en utilisant les vis et écrous (15) tel qu'illustré. Répéter pour les barres de structure de toit (S) restantes.
- 11.2 Joindre la barre centrale de toit (O) entre les deux connecteurs (18) tel qu'illustré. Attacher en utilisant les vis (20).
- 11.3 Attacher les barres de toit (M) aux barres de structure de toit (S) en utilisant les vis (14) tel qu'illustré.

Parts required for this step / Pièces requises pour cette étape :

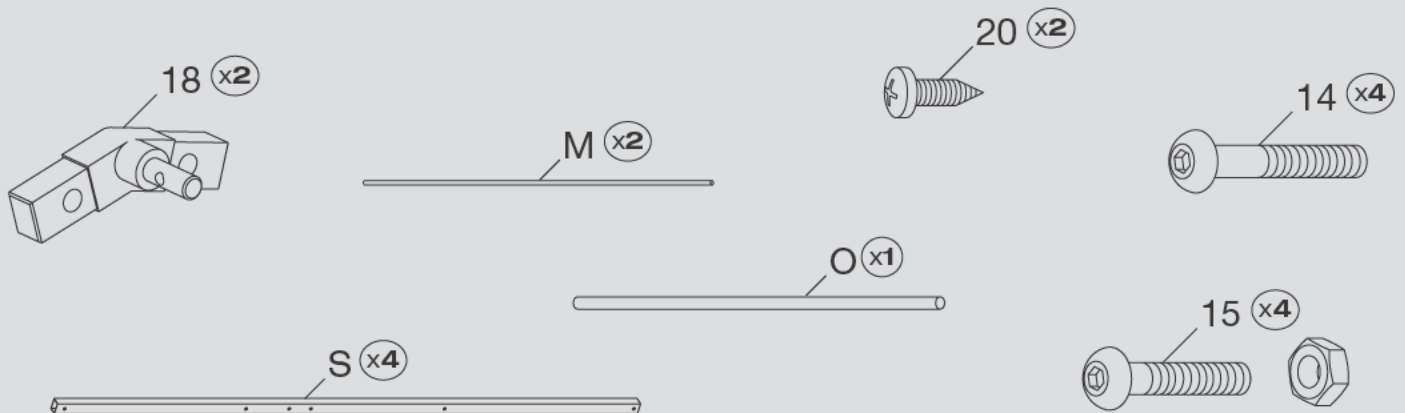



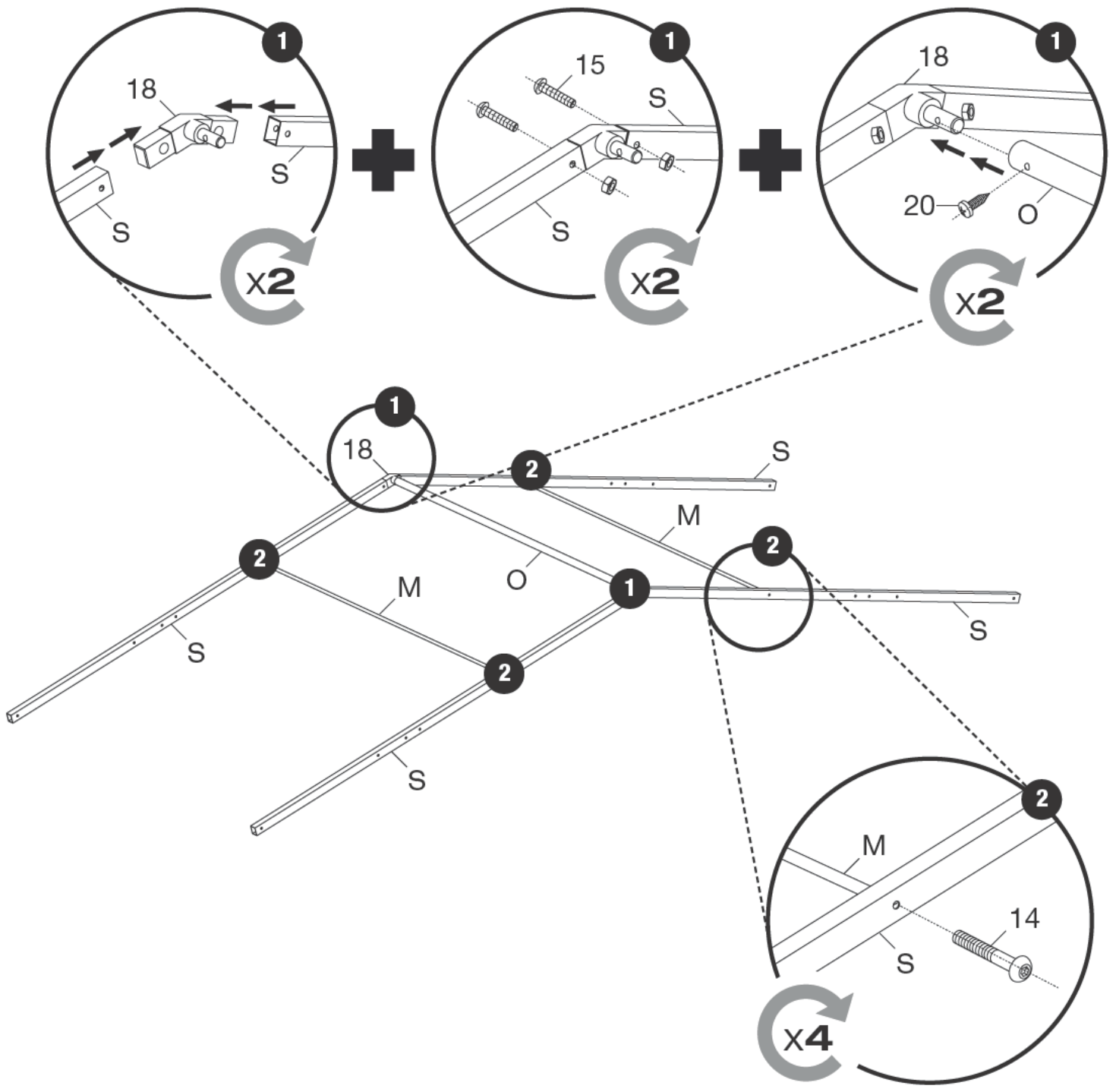

## Step 12

- 12.1 Attach the roof structure bars (S) to the roof structure (Q and Q1) using the screws and nuts (13) as illustrated.

## Étape 12

- 12.1 Attacher les barres de structure de toit (S) aux montants de toit (Q et Q1) en utilisant les vis et écrous (13) tel qu'illustré.

Parts required for this step / Pièces requises pour cette étape :

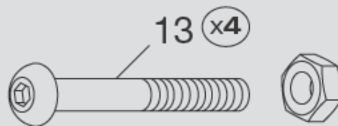

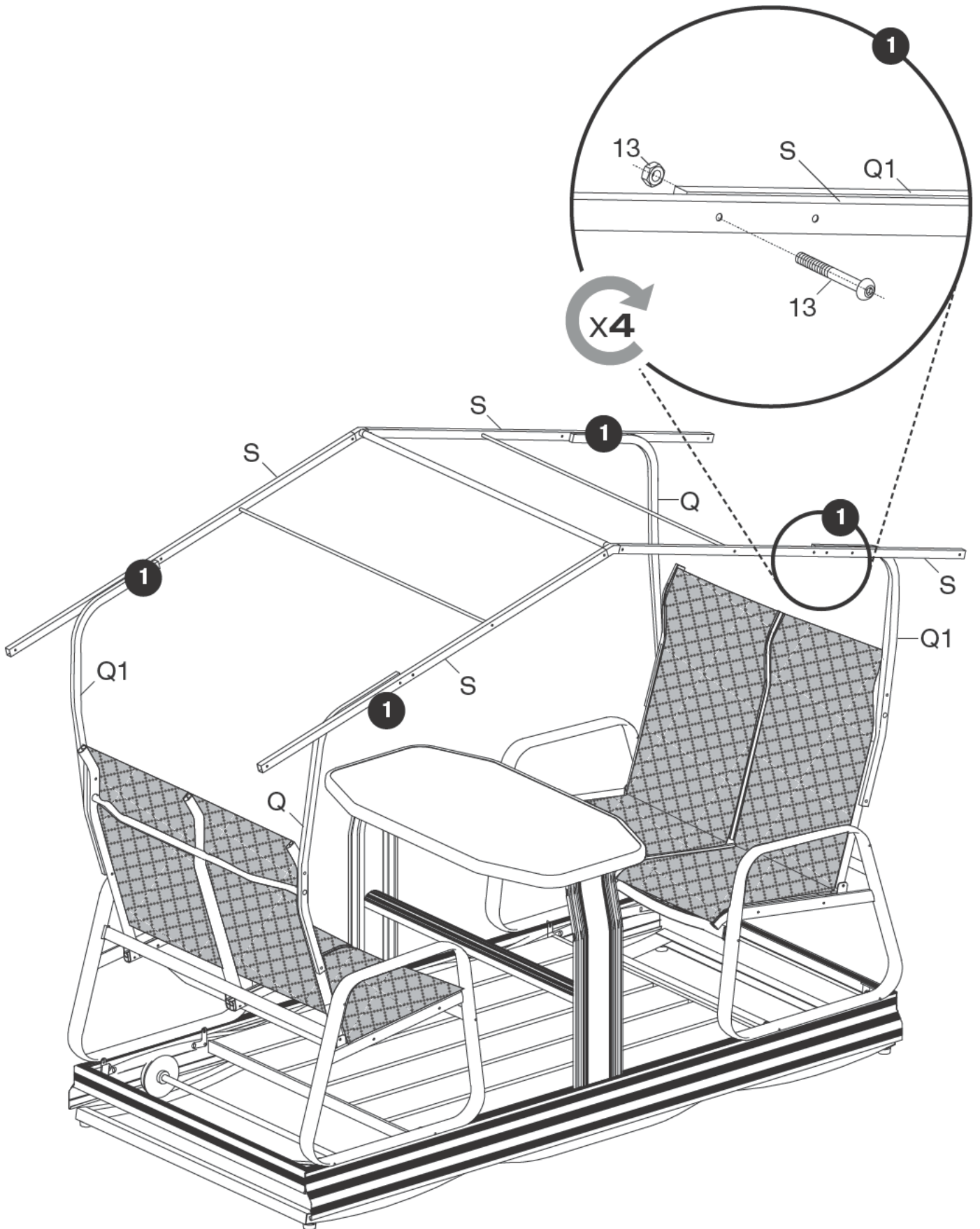

## Step 13

- 13.1 Attach the roof bars (N) to the roof structure (Q and Q1) using the screws (16) as illustrated. Each screw (16) must be inserted into the roof structure bar (S), then the roof structure (Q or Q1) and finish into the roof bar (N).

## Étape 13

- 13.1 Attacher les barres de toit (N) aux montants de toit (Q et Q1) en utilisant les vis (16) tel qu'illustré. Chaque vis (16) doit d'abord être insérée dans une barre de structure de toit (S) puis dans un montant de toit (Q ou Q1) et terminer dans une barre de toit (N).

Parts required for this step / Pièces requises pour cette étape :

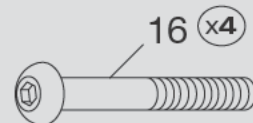

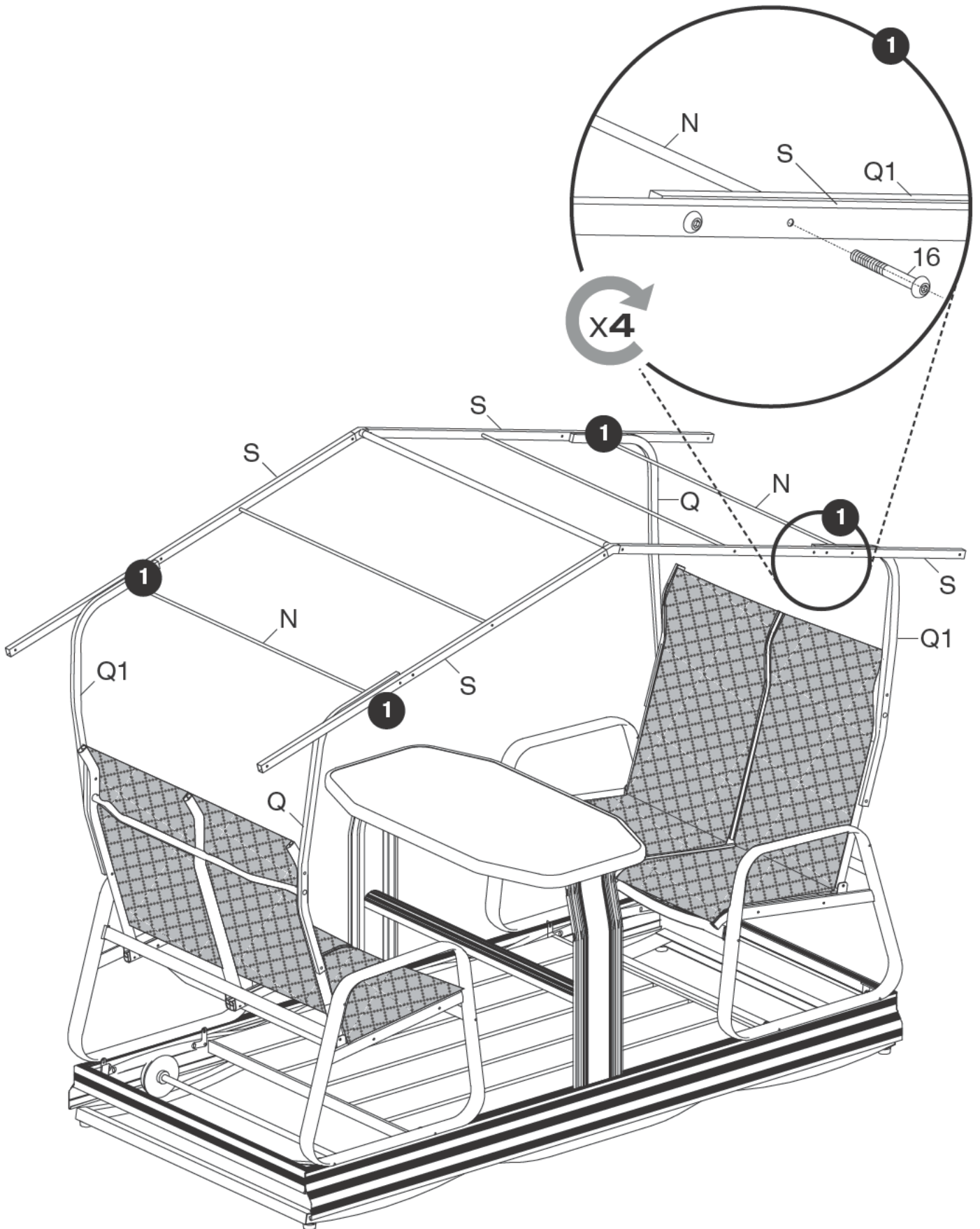

## Step 14

- 14.1 Slide a roof bar (P) at each extremity of the roof (R) as illustrated.
- 14.2 Cover the top of the structure with the roof (R) and attach the roof to the structure using the velcro.

## Étape 14

- 14.1 Glisser une barre de toit (P) à chaque extrémité du toit (R) tel qu'illustré.
- 14.2 Couvrir le dessus de la structure avec le toit (R) et attacher le toit à la structure en utilisant les velcros.

Parts required for this step / Pièces requises pour cette étape :

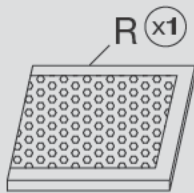

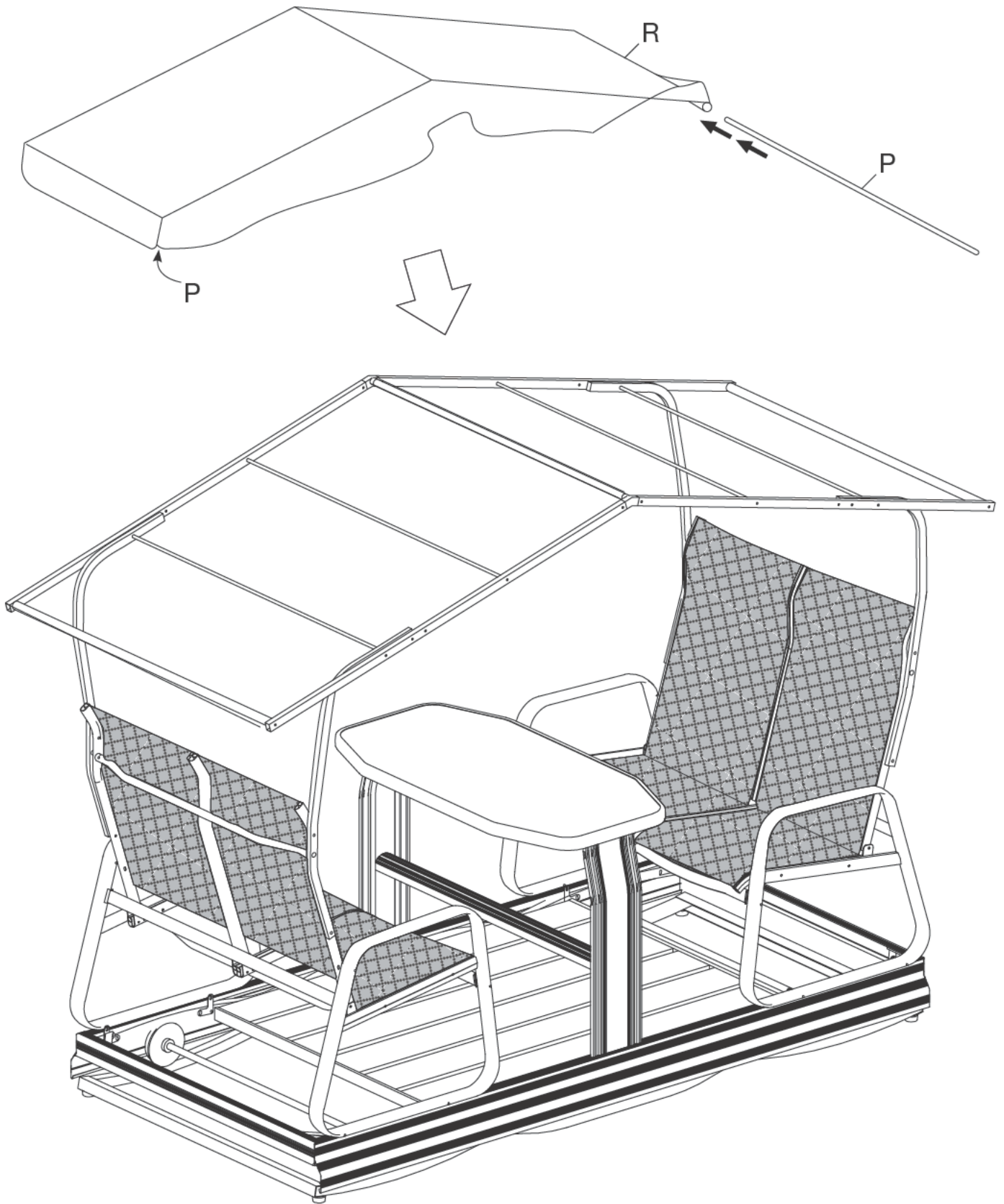



## Step 15

- 15.1 Attach the roof bar (P) to the roof structure bars (S) using the screws (14) as illustrated.  
Repeat for remaining roof bar (P).

## Étape 15

- 15.1 Attacher la barre de toit (P) aux barres de structure de toit (S) en utilisant les vis (14) tel qu'illustré.  
Répéter pour la barre de toit (P) restante.

Parts required for this step / Pièces requises pour cette étape :

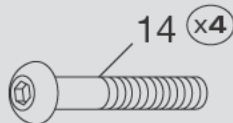



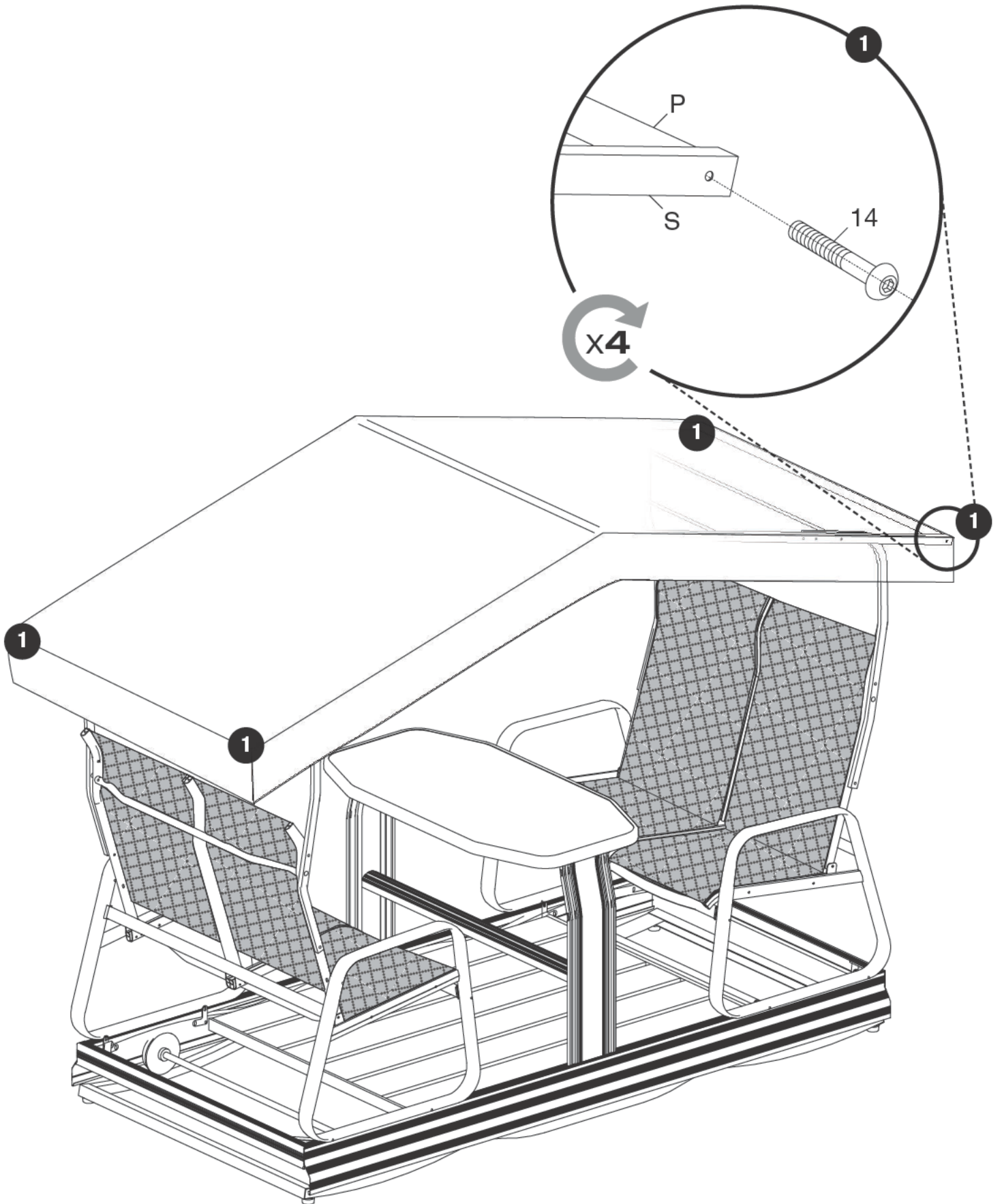





**SOJAG** ■ I  
[www.sojag.ca](http://www.sojag.ca)